

THIS DRAWING IS UNPUBLISHED. RELEASED FOR PUBLICATION  
 © COPYRIGHT BY TYCO ELECTRONICS CORPORATION. ALL RIGHTS RESERVED.

LOC	DIST	REVISIONS					
AG	00	P	LTR	DESCRIPTION	DATE	DWN	APVD
		G1		REV PER ECO-06-013364	12OCT2006	BC	JH

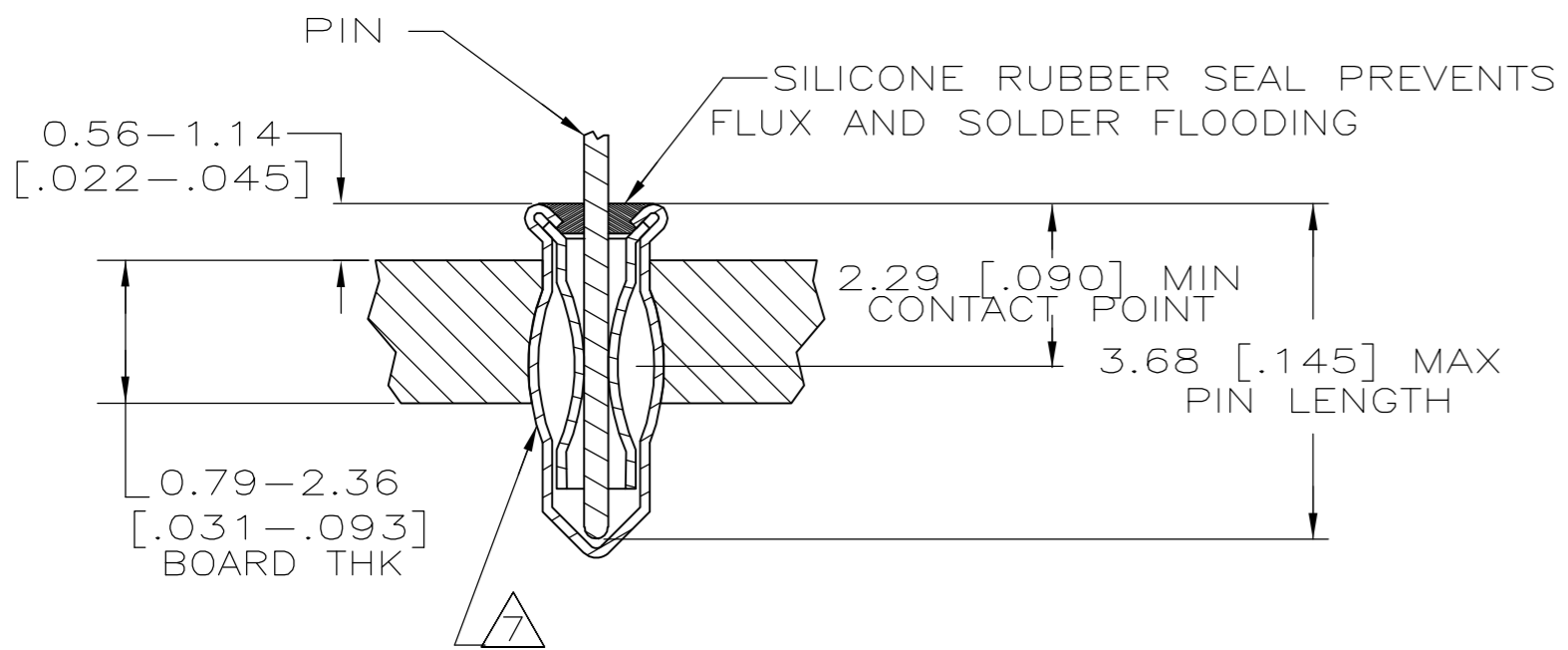
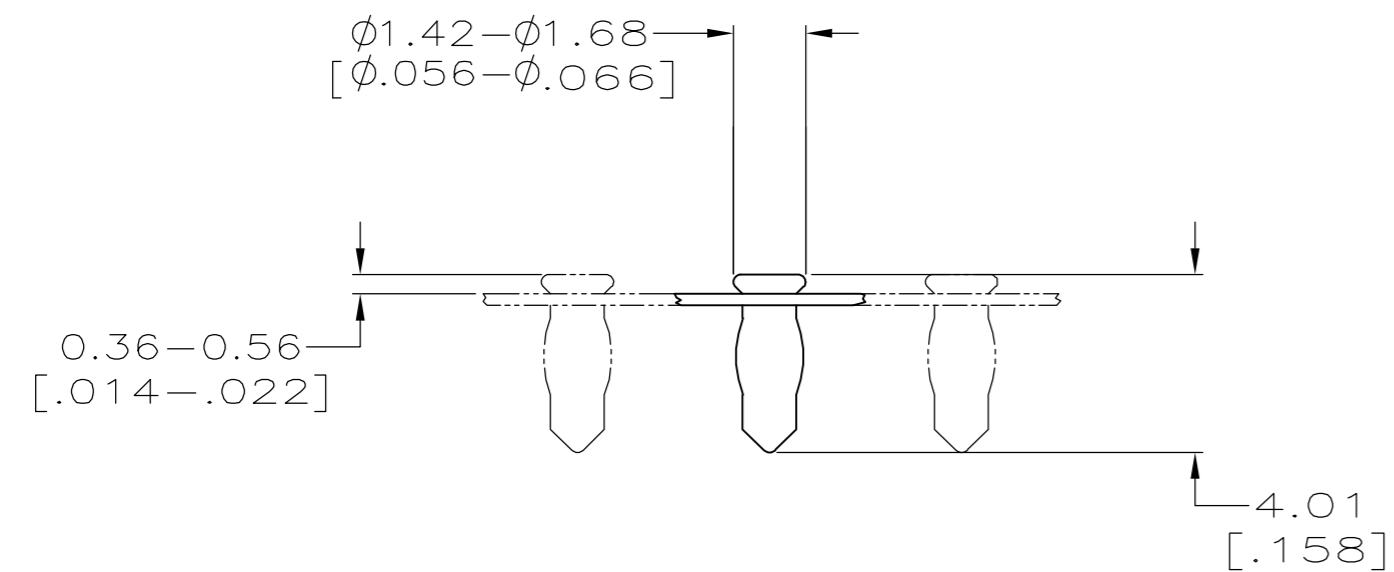
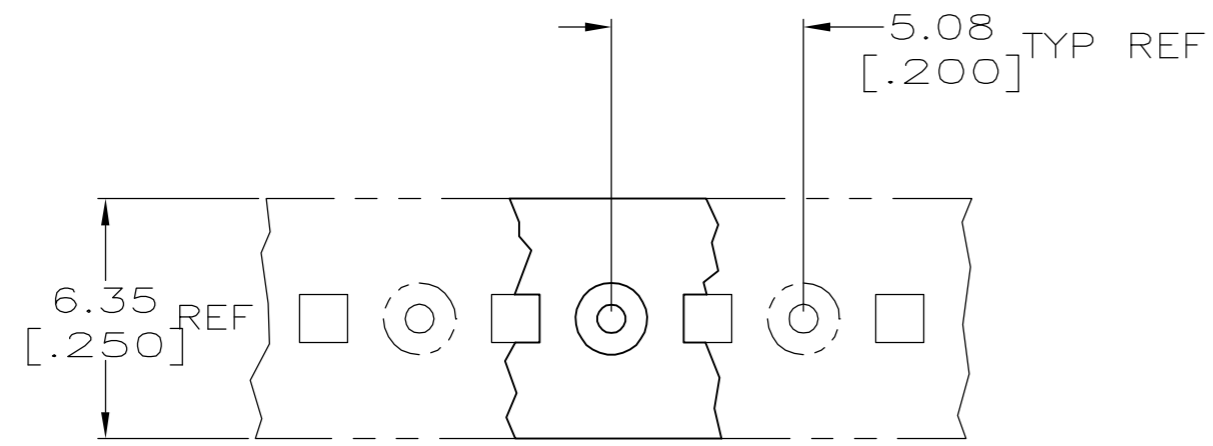

- 1 MATERIAL:  
EYELET - COPPER (QQ-C-576)  
SPRING - BERYLLIUM COPPER (QQ-C-533)  
SEALANT - SILICONE RUBBER
- 2 TIN PLATE (MIL-T-10727)0.00381 [.000150] MIN THK.
- 3 TIN PLATE(MIL-T-10727)0.00254 [.000100] MIN THK.
- 4 GOLD PL(MIL-G-45204)0.00076 [.000030] MIN THK ON CONTACT AREA.
- 5 PACKAGED 50,000 PER REEL
- 6 TO INSURE 1/2 OZ MIN RETENTION DO NOT EXCEED 0.10 [.004] DIFFERENCE IN PIN DIA WHEN CHANGING TO A SMALLER DIA PIN
- 7 PRODUCT IS OVALIZED FOR RETENTION IN THE P.C. BOARD. THE RECOMMENDED HOLE DIAMETER IS 1.07 [0.042] MINIMUM, +0.08 [.003] MAX. PRIOR TO SOLDERING.
- 8 TIN-LEAD PLATE 0.00381 [.000150] MIN THK.
- 9 PACKAGED 10,000 PER REEL

	2.29-3.68 [.090-.145]	Ø0.38-Ø0.53 [Ø.015-Ø.021]	GOLD 4	TIN 2	5	1-645947-7
	2.29-3.68 [.090-.145]	Ø0.38-Ø0.53 [Ø.015-Ø.021]	GOLD 4	TIN 8	9	1-645947-6
	2.29-3.68 [.090-.145]	Ø0.30-Ø0.46 [Ø.012-Ø.018]	GOLD 4	TIN 2	9	1-645947-5
	2.29-3.68 [.090-.145]	Ø0.30-Ø0.46 [Ø.012-Ø.018]	TIN 3	TIN 2	9	1-645947-4
OBSOLETE	2.29-3.68 [.090-.145]	Ø0.38-Ø0.53 [Ø.015-Ø.021]	GOLD 4	TIN 2	9	1-645947-2
SUPERSEDED BY 645947-1	2.29-3.68 [.090-.145]	Ø0.38-Ø0.53 [Ø.015-Ø.021]	TIN 3	TIN 2		1-645947-1
	2.29-3.68 [.090-.145]	Ø0.38-Ø0.53 [Ø.015-Ø.021]	GOLD 4	TIN 2	5	645947-2
OBSOLETE	2.29-3.68 [.090-.145]	Ø0.38-Ø0.53 [Ø.015-Ø.021]	TIN 3	TIN 2	5	645947-1
	LENGTH	DIA	FINISH			PART NO
			SPRING	EYELET		

THIS DRAWING IS A CONTROLLED DOCUMENT.

DIMENSIONS: INCHES	TOLERANCES UNLESS OTHERWISE SPECIFIED: 0 PLC ± - 1 PLC ± - 2 PLC ± - 3 PLC ± 0.20[.008] 4 PLC ± - ANGLES ± - FINISH	DWN M.BOWERS 12-20-82 CHK P.MUTZABAUGH 6-10-85 APVD G.MILLER 6-10-85 PRODUCT SPEC APPLICATION SPEC 114-26004 WEIGHT - CUSTOMER DRAWING	Tyco Electronics Corporation Harrisburg, PA 17105-3608 NAME: MINIATURE SPRING SOCKET ASSY SERIES 1 SHORT WITH SEALANT SIZE: A2 CAGE CODE: 00779 DRAWING NO: 645947 RESTRICTED TO: - SCALE: NTS SHEET: 1 of 1 REV: G1
--------------------	--	---	---

645947